

# MVE 600/1400 SERIES



The MVE 600 and 1400 Cryo-Preservation Systems are designed to provide reliable storage of biological products in liquid or vapor. New design with improved ergonomics and easier sample access, all aluminum cabinet and lid with stainless steel top deck. With vial storage capacities ranging from 16,900 to 26,650, combined with our low maintenance design, industry leading warranty, and the TEC 2000 electronics the MVE 600 and 1400 Series are world class wide neck freezers.

\*The MVE 600/1400 Series Freezers are designed primarily for liquid phase storage. If vapor phase storage is required, ask your distributor about the available vapor phase storage accessory package.

## Accessories:

- Inventory Frames and Cassettes
- Square Racks - stainless or aluminum
- Cardboard Boxes
- Plastic Boxes
- Cryogenic Gloves
- Transfer Hose (Standard)

## Options:

- Battery Back-Up
- Gas Bypass

# MVE 600/1400 SERIES



## Specifications

MODEL	MVE 600	MVE1400
<b>MAXIMUM STORAGE CAPACITY</b>		
Number of 1.2 & 2.0 ml vials in racks (13/2)	16,900	26,650
Number of racks (100 vials)	12	18
Number of racks (25 vials)	4	10
Total number of racks	16	28
No of Blood Bags Stored (Fenwal 4R-9953)	352	512
<b>PERFORMANCE</b>		
Liquid nitrogen capacity (liters)	236	375
Power supply	24 VDC	24 VDC
<b>UNIT DIMENSIONS</b>		
Neck opening (in/mm)	25.13 / 638	31.75 / 806
Usable height (in/mm)	29.06 / 738	28.9 / 735
Overall height (in/mm)	40.38 / 1026	40.38 / 1026
Outside dimensions (in/mm)	28x35.13 / 711x892	34.75x41.13 / 882x1044
Internal diameter (in/mm)	25.13 / 638	31.75 / 806
Weight empty (lbs/kg)	330 / 150	530 / 240
Weight full (lbs/kg) w/LN2	751 / 341	1198 / 543

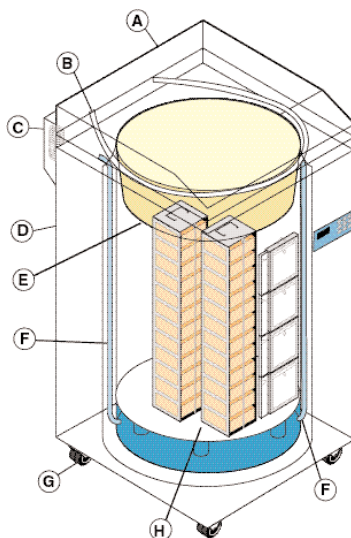

- A Durable, aluminum lid - designed for longer life
- B Advanced gasket design restricts ambient air flow into freezer
- C Industrial-strength hinges
- D Aluminum cabinet eliminates rust
- E Low stainless steel deck for easy access and durability
- F IAnnular filling lines to reduce frost and ice formation
- G Tough, durable casters
- H Optional vapor platform

**TWO Year Standard Warranty**

**FIVE Year Vacuum Warranty**

**Conforms to MDD 93/42/EEC, the Medical Device Directive for the EU.**

MVE Bio-Medical, Chart Industries, Inc.  
 1800 Sandy Plains Industrial Parkway, Suite 316  
 Phone: 770-425-4470 . 888-683-2796 Local Fax: 770-425-4740 . www.chartbiomed.com



Innovation. Experience. Performance.™